

FLEXIRIDE® CARTRIDGE AXLES DATA SHEET

2,000/1,400 LBS SPINDLE DIMENSIONS

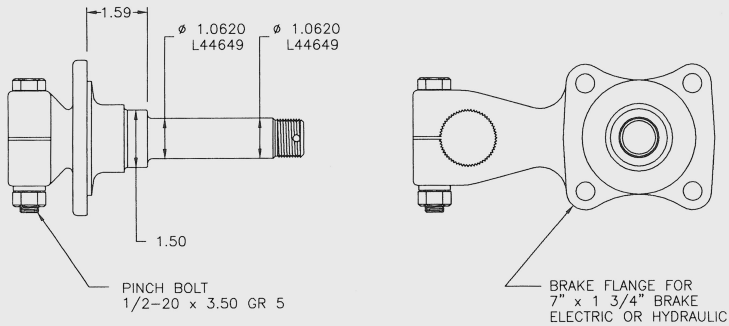

3,500/2,500 LBS SPINDLE DIMENSIONS

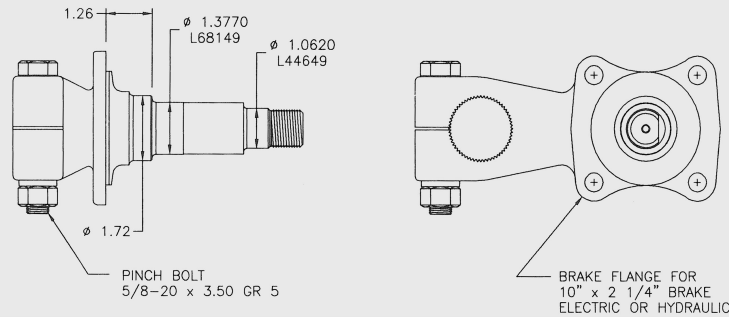

7,000/5,200 LBS SPINDLE DIMENSIONS

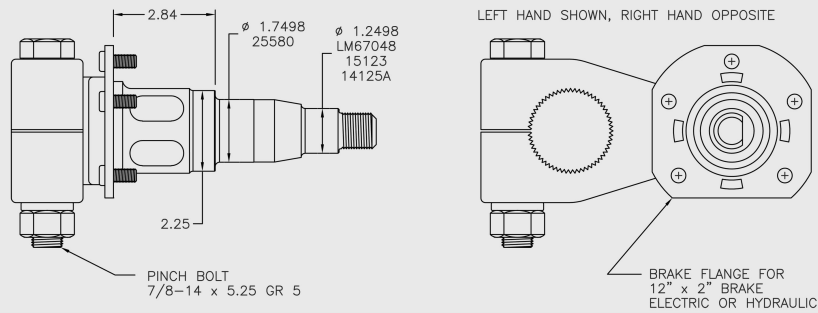

2,000/1,400 LBS AXLE DIMENSIONS

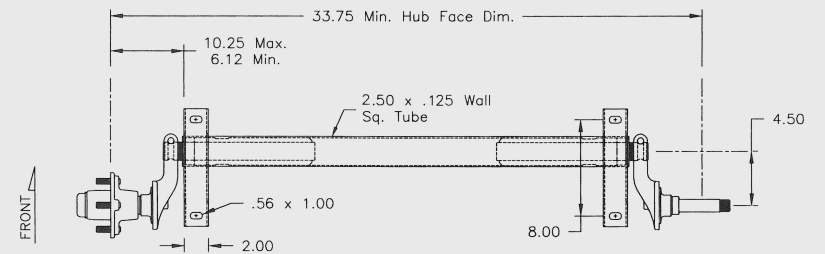

3,500/2,500 LBS AXLE DIMENSIONS

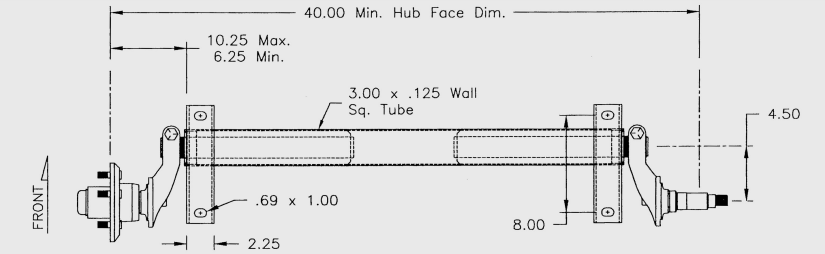

7,000/5,200 LBS AXLE DIMENSIONS

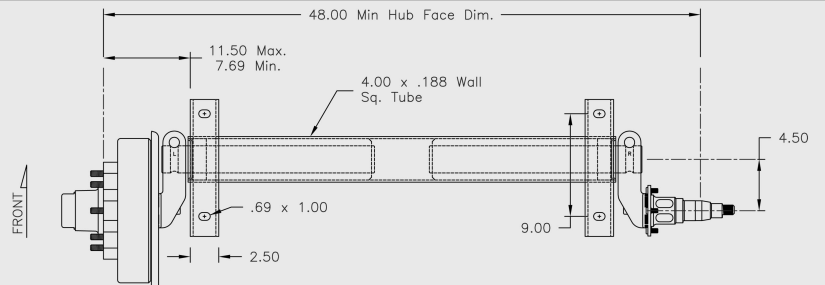

The minimum hub face offset provides the strongest axle. With stronger tubing the maximum offset can be increased for special applications.



For more information call or write:

The Universal Group Corp.™

1025 Thomas Busch Mem. Highway, Pennsauken, NJ 08110

Tel: (856) 488-1800 • Tel: (800) 777-1823 • Fax: (856) 488-9636 • Fax: (800) 360-9636

E-mail: info@theuniversalgroup.com • Website: www.theuniversalgroup.com

South Cooper Business Park, 1120 Eden Road, Suite 100, Arlington, TX 76001

Tel: (800) 637-4422 • Tel: (817) 417-6812 • Fax: (800) 360-9636

